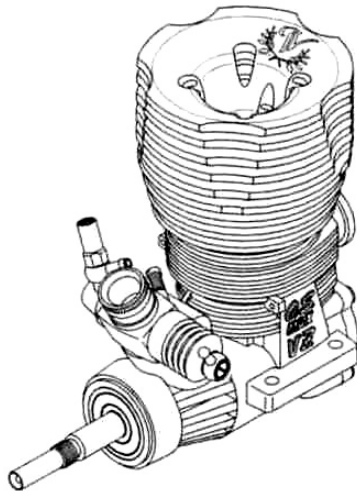

O.S. ENGINE

MAX-21VZ-B V-Spec

OWNER'S INSTRUCTION MANUAL

It is of vital importance, before attempting to operate your engine, to read the general **'SAFETY INSTRUCTIONS AND WARNINGS'** section on pages 2-5 of this booklet and to strictly adhere to the advice contained therein.

- Also, please study the entire contents of this instruction manual, so as to familiarize yourself with the controls and other features of the engine.
- Keep these instructions in a safe place so that you may readily refer to them whenever necessary.
- It is suggested that any instructions supplied with the vehicle, radio control equipment, etc., are accessible for checking at the same time.



CONTENTS

SAFETY INSTRUCTIONS AND WARNINGS ABOUT YOUR O.S. ENGINE ----	2-5	STARTING THE ENGINE & RUNNING-IN---	16-19
ENGINE CONSTRUCTION-----	6	FINAL ADJUSTMENT-----	20-22
NOTES WHEN APPLYING AN ELECTRIC STARTER -----	7	CARBURETOR CLEANLINESS-----	22
ABOUT THE ENGINE-----	8	CARE AND MAINTENANCE -----	23-24
BEFORE STARTING-----	9-11	CHECKING THE ENGINE -----	24
BASIC ENGINE PARTS -----	11	GUARANTEE-----	25
CARBURETOR CONTROLS-----	12	TROUBLE SHOOTING-----	26-29
GLOWPLUG-----	13	ENGINE EXPLODED VIEW & PARTS LIST ---	30-31
INSTALLATION OF THE STANDARD ACCESSORIES-----	14	CARBURETOR EXPLODED VIEW & PARTS LIST-----	32-33
INSTALLATION-----	15	O.S. GENUINE PARTS & ACCESSORIES ----	34-35
		THREE VIEW DRAWING-----	36

SAFETY INSTRUCTIONS AND WARNINGS ABOUT YOUR O.S. ENGINE

Remember that your engine is not a "toy", but a highly efficient internal-combustion machine whose power is capable of harming you, or others, if it is misused.

As owner, you, alone, are responsible for the safe operation of your engine, so act with discretion and care at all times.

If at some future date, your O.S. engine is acquired by another person, we would respectfully request that these instructions are also passed on to its new owner.

- The advice which follows applies basically to ALL MODEL ENGINES and is grouped under two headings according to the degree of damage or danger which might arise through misuse or neglect.



WARNINGS

These cover events which might involve serious (in extreme circumstances, even fatal) injury.



NOTES

These cover the many other possibilities, generally less obvious sources of danger, but which, under certain circumstances, may also cause damage or injury.



WARNINGS

- Model engine fuel is poisonous. Do not allow it to come into contact with the eyes or mouth. Always store it in a clearly marked container and out of the reach of children.



- Model engine fuel is also highly flammable. Keep it away from an open flame, excessive heat, sources of sparks, or anything else which might ignite it. Do not smoke or allow anyone else to smoke, near to it.



- Never operate your engine in an enclosed space. Model engines, like automobile engines, exhaust deadly carbon-monoxide. Run your engine only in an open area.

- Model engines generate considerable heat. Do not touch any part of your engine until it has cooled. Contact with the muffler (silencer), cylinder head or exhaust header pipe, in particular, may result in a serious burn.





NOTES

- This engine is intended for model cars. Do not attempt to use it for any other purpose.
- Mount the engine in your model securely, following the manufacturers' recommendations, using appropriate screws and locknuts.
- Install an effective silencer (muffler). Frequent close exposure to a noisy exhaust (especially in the case of the more powerful highspeed engines) may eventually impair your hearing and such noise is also likely to cause annoyance to others over a wide area.
- The wearing of safety glasses is also strongly recommended.
- Take care that the glowplug clip or battery leads do not come into contact with rotating parts. Also check that the linkage to the throttle arm is secure.
- For their safety, keep all onlookers (especially small children) well back (at least 20 feet or 6 meters) when preparing your model for running.



NOTES

- To stop the engine, fully retard the throttle stick and trim lever on the trans-mitter, or, in an emergency, cut off the fuel supply by pinching the fuel delivery line from the tank.
- Warning! Immediately after a glowplug-ignition engine has been run and is still warm, conditions sometimes exist whereby it is just possible for the engine to abruptly restart if it is rotated over compression **WITHOUT** the glowplug battery being reconnected.

ENGINE CONSTRUCTION

With this engine, the piston will feel tight at the top of its stroke (TDC) when the engine is cold. This is normal. The cylinder bore is a little tapered. The piston and cylinder are designed to achieve a perfect running clearance when they reach their running temperatures.

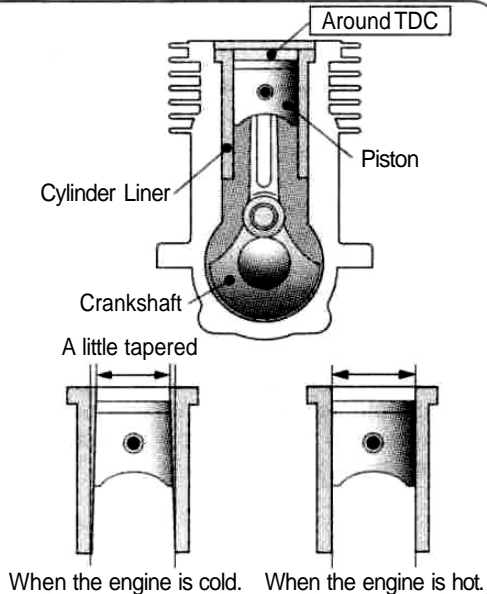

NOTES WHEN APPLYING AN ELECTRIC STARTER

Do not over-prime. This could cause hydraulic lock and damage the engine on application of the electric starter.

If over-primed, remove glowplug, close needle-valve and apply starter to pump out surplus fuel. Cover the head with waste to prevent pumped out fuel coming into your eyes.

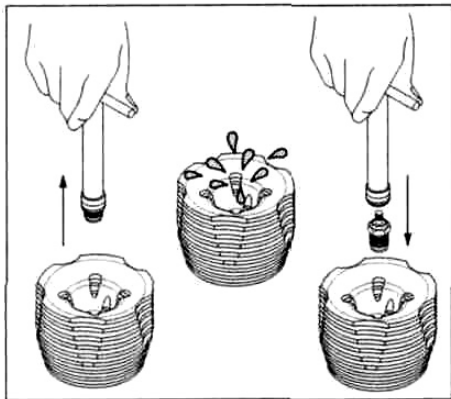

NOTE

As delivered, the engine has its carburetor lightly fit into its intake. Secure it changing its angle according to the car chassis.

ABOUT THE ENGINE

The MAX-21 VZ-B V-Spec is a high performance 3.5cc class power unit for one-eight-scale radio-controlled 'off-road' or 'buggy' cars. It has been expressly designed for racing competitions.

T-type plug (turbo plug) design improves the power, fuel consumption and durability.

The new 21 C carburetor is supplied with 8mm and 9mm dia. reducers to manage different course conditions.

Standard accessories

- Glow Plug P3 T-type head (Turbo head) 1piece (Hot Type)



- Cylinder-head gasket (0.1mm) 1 sheet



- Exhaust Seal Ring 1 piece



- Carburetor Reducer 8mm (Red) 1 piece (w/ "O" Ring)



- Dust Cap 03,016,018 every 1piece

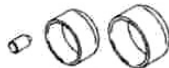

BEFORE STARTING

Tools, accessories, etc. The following items are necessary for operating the engine.

■ Optional Extras

GLOW PLUG T-Type (Turbo Plug)

P3 is supplied with the engine. As replacement, suggested O.S. plugs are P3 and P6.



SUPER AIR CLEANER 203 ASSEMBLY

This is a heavy-duty wet type air cleaner designed specifically for 3.5cc 'off-road' model car engines.



T-2050 EXHAUST HEADER PIPE ASSEMBLY

This is designed to use with the T-2050 Tuned Silencer

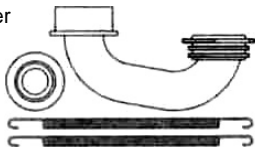

T-2050 TUNED SILENCER ASSEMBLY

This is designed specifically for 3.5cc 'off-road' model car engines.

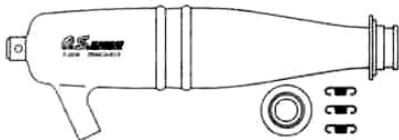

T-2050 TUNED SILENCER COMPLETE SET

This is a set of T-2050 Tuned Silencer and T-2050 Exhaust Header Pipe Assembly.

■ TOOLS

HEX WRENCH

Necessary for engine installation.
1.5mm, 2mm, 2.5mm, 3mm opposite side



SCREWDRIVER

Necessary for carburetor adjustments.
No.1, No.2, etc



LONG SOCKET WRENCH WITH PLUG GRIP

Recommended for easy removal and replacement of the angled and recessed glowplug, the O.S. Long Socket Wrench incorporates a special grip.

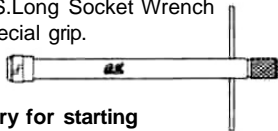

■ Items necessary for starting FUEL

Generally, it is suggested that the user selects a fuel that is commercially available for model two-stroke engines and contains 10-30% nitromethane. As a starting point, we recommend a fuel containing 20% nitromethane, changing to a fuel containing more nitro if necessary. When the brand of fuel is changed, or the nitro content increased, it is advisable to repeat the running-in procedure referred to in the RUNNING-IN paragraphs. Please note that with high-nitro fuels, although power may be increased for competition purposes, glowplug elements do not last as long and engine life will be shortened.

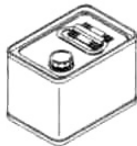

REMINDER!



Model engine fuel is poisonous. Do not allow it to come into contact with the eyes or mouth. Always store it in a clearly marked container and out of the reach of children.



Model engine fuel is also highly flammable. Keep it away from open flame, excessive heat, sources of sparks, or anything else which might ignite it. Do not smoke or allow anyone else to smoke, near to it.

FUEL FILTER

To fit in the fuel line between fuel tank and carburetor to prevent dust coming into the carburetor.



GLOWPLUG IGNITER

Commercially available handy glowplug heater in which the glowplug battery and battery leads are integrated.

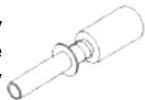

STARTER BOX

For starting the engine.

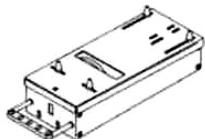

7.2V BATTERIES FOR STARTER BOX

Batteries for starter box. Select according to the starter box used. Be sure to full charge before using.

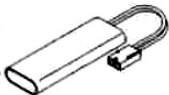

FUEL PUMP

For filling the fuel tank, a simple, polyethylene "squeeze" bottle, with a suitable spout, is required.



SILICONE FUEL LINE

Heatproof silicone tubing of approx. 5mm o.d. and 2mm i.d. is required for the connection between the fuel tank and engine.



BASIC ENGINE PARTS

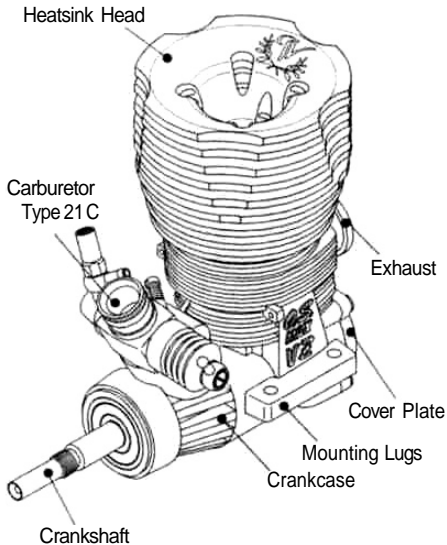

CARBURETOR CONTROLS

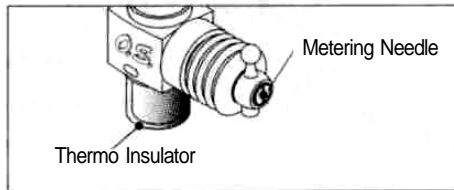
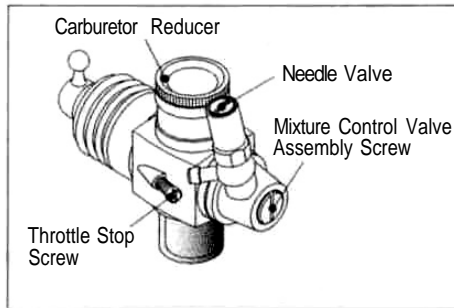

Four adjustable controls are provided on this carburetor.

- **The Needle-Valve:**

For adjusting the mixture strength when the throttle is fully open.

- **The Mixture Control Screw:**

For changing the mixture strength at mid speed and acceleration. (Do not rotate the screw more than one turn.)

- **The Metering Needle:**

For adjusting the mixture strength at part-throttle and idling speeds, to obtain steady idling and smooth acceleration to mid speeds.

- **The Throttle Stop Screw:**

For setting the minimum idling speed:

NOTE: Readjustment may be necessary, occasionally to allow for changes in fuel formula gear ratio or clutch engagement point.

GLOWPLUG

Since the compatibility of glowplug and fuel may have a marked effect on performance and reliability, it may be worthwhile to choose the R/C type plug found most suitable after tests. Recommended O.S. plugs are P3 and P6. Carefully install plug finger-tight, before final tightening with the correct size plug wrench.

The role of the glowplug

With a glowplug engine, ignition is initiated by the application of a 1.5-volt power source. When the battery is disconnected, the heat retained within the combustion chamber remains sufficient to keep the plug filament glowing, thereby continuing to keep the engine running. Ignition timing is 'automatic' : under reduced load, allowing higher rpm, the plug becomes hotter and, appropriately, fires the fuel/air charge earlier; conversely, at reduced rpm, the plug become cooler and ignition is retarded.

Glowplug life

Particularly in the case of very high performance engines, glowplugs must be regarded as expendable items. However, plug life can be extended and engine performance maintained by careful use, i.e.:

- Install a plug suitable for the engine.
- Use fuel containing a moderate percentage of nitromethane unless more is essential for racing events.
- Do not run the engine too lean and do not leave the battery connected while adjusting the needle.

When to replace the glowplug

Apart from when actually burned out, a plug may need to be replaced because it no longer delivers its best performance, such as when:

- Filament surface has roughened and turned white.
- Filament coil has become distorted.
- Foreign matter has adhered to filament or plug body has corroded.
- Engine tends to cut out when idling.
- Starting qualities deteriorate.

INSTALLATION OF THE STANDARD ACCESSORIES

Fitting the glow plug. Insert P3 plug supplied into heatsink-head carefully, making sure that it is not cross-threaded before tightening firmly. (All the O.S. T-Type plugs including the P3 are not supplied with a washer.)

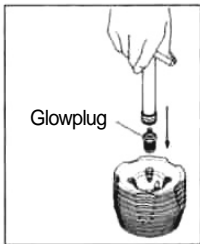

Install the exhaust seal ring supplied.

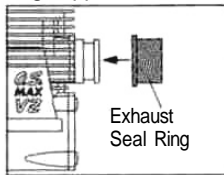

The engine is fit with one each of 0.1mm and 0.2mm cylinder-head gasket when it leaves the factory. Another 0.1mm head gasket is supplied with the engine. You may add it at initial running-in, when a glow plug tends to burn out due to high temperature and / or high humidity or when you prefer fuel economy to power.

Fitting the carburetor reducer

Replace the reduce according to the course conditions.

9mm (Blue)

Fitted with the carburetor when leaves the factory. Suitable for high speed (wide) and flat course which requires power.

8mm (Red)

Supplied with the engine. Replace when required. Suitable for technical (narrow) and bumpy course and when less fuel consumption is more important.

INSTALLATION OF THE DUST CAP SET

In case engine is kept, an exhaust port, a carburetor, etc. are equipped and penetration of the foreign substance inside engine is prevented.

INSTALLATION OF THE CARBURETOR

As delivered, the engine has its carburetor lightly installed in the intake boss. Secure it as follows.

1. Loosen the retainer screw, rotate the carburetor to its correct position and make sure that it is pressed well down into the intake boss, compressing the rubber gasket, before retightening screw.
2. Rotate the retainer screw gently until it stops, then tighten a further 120-180 degrees. Do not overtighten the screw as this will damage the carburetor body.

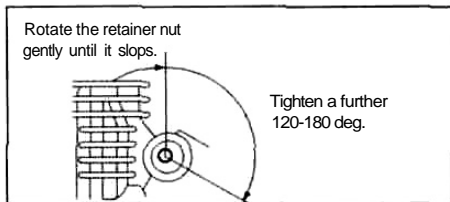

ENGINE INSTALLATION

Make sure that the vehicle's engine mounting surfaces are level and in the same plane. Poor installation may cause distortion of the crankcase, bearings, etc., resulting in erratic running and loss of performance.

The recommended screws for securing the engine are 3mm or 4-40 steel Allen hexagon socket type.

If existing holes in the engine mount do not align perfectly with engine mounting lugs, enlarge them slightly with a needle-file so that screws are in alignment with the mounting holes.

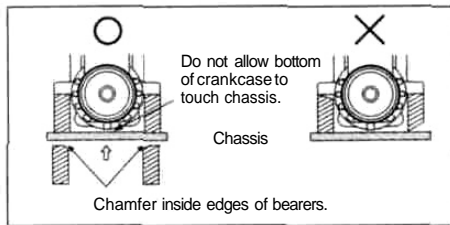

STARTING THE ENGINE & RUNNING-IN ("Breaking-in")

For long life and high performance, every engine needs to be 'run-in' or 'broken-in'. With care, running-in of the MAX-21VZ-B V-Spec can be carried out with the engine installed in the vehicle. Be sure to install the air-cleaner on the carburetor and use a muffler-pressurized fuel system.

The following procedure is suitable for these engines when the O.S. T-2050 tuned silencer and a fuel containing up to 30% nitromethane are used.

- ◆ Fill the tank completely with fuel.

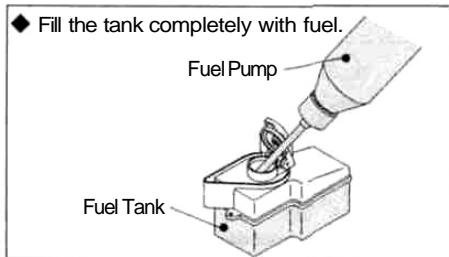

- ◆ Temporarily remove the glowplug to check that it glows bright red when energized.

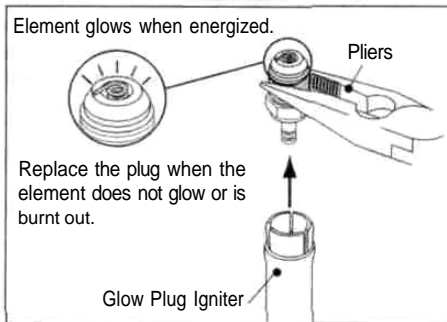

- ◆ Turn the needle-valve clockwise slowly until it stops. This is the fully closed position. Do not force to turn further.
- ◆ Open the Needle-Valve 3 turns from the fully closed position.
- ◆ Switch on the transmitter and receiver and set the throttle very slightly open from the idling position.

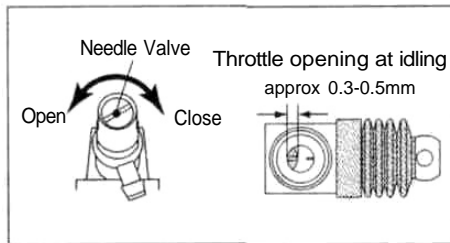

Note:
Throttle opening at idling should be checked before fitting an air cleaner.

- ◆ Turn the engine with starter box to draw the fuel into the engine.

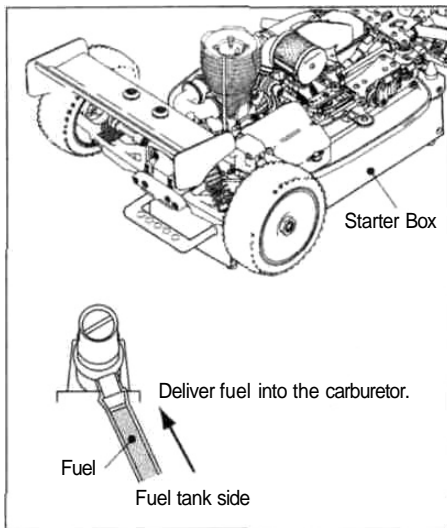

- ◆ Now connect glowplug battery lead to heat the plug filament and start the engine.

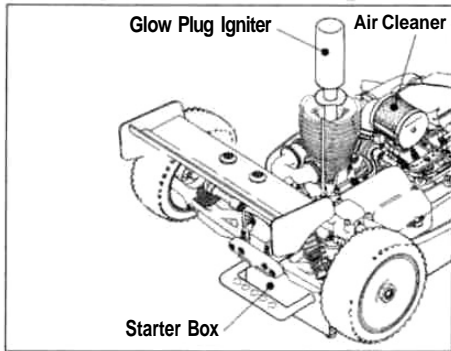

Attention:

It is vitally important to set the throttle at the correct position before starting the engine. If the engine is allowed to run with the throttle too far open under "no load" conditions (i.e. with the driving wheels not in contact with



- ◆ When the engine starts, first allow it to operate in short runs at the very rich starting settings, with the glowplug battery still connected and the driving wheels clear of the ground. The rich mixture will, under these conditions, provide adequate lubrication and cooling, indicated by profuse smoke from the exhaust.

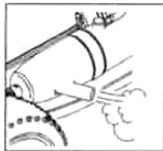

- ◆ Next, disconnect the glowplug battery and try running the car on the track. If the engine stalls, open the throttle fractionally, but try to keep the engine running as rich as possible: if it stops because of being excessively over-rich, close the Needle-Valve 30° and try again.

- ◆ Run the car on the track until one tank of fuel has been consumed, then close the Needle-Valve 30° and run the car for another full tank of fuel. Repeat this procedure until 1/2 gallon of fuel have been consumed, during which time the throttle may be opened for brief bursts of increased power.

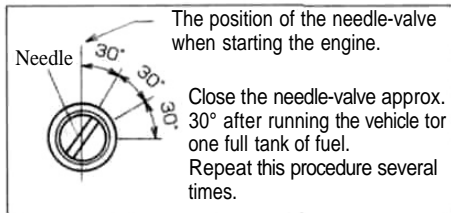

Note:

If the engine should need to be disassembled (e.g. for cleaning or minor parts replacement), it is advisable to return the needle-valve to the original rich, starting setting and check whether further running-in time is required before the car is raced

again. In the event of any major working parts (e.g. piston/cylinder liner assembly) being replaced or the fuel being changed, especially to high nitro fuel, the complete running-in should be repeated.

- ◆ To stop the engine, close the throttle to idling speed, then shut it off completely with the trim lever on the transmitter. To cut off the fuel supply, pinch the fuel delivery tube to the carburetor.

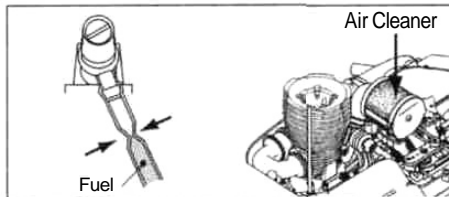

Warning!

Do not touch rotating parts, engine and silencer when stopping the engine as they become very hot, and contact with them may result in a serious burn.

FINAL ADJUSTMENT

Final adjustment should be carried out only after the running-in has been completed.

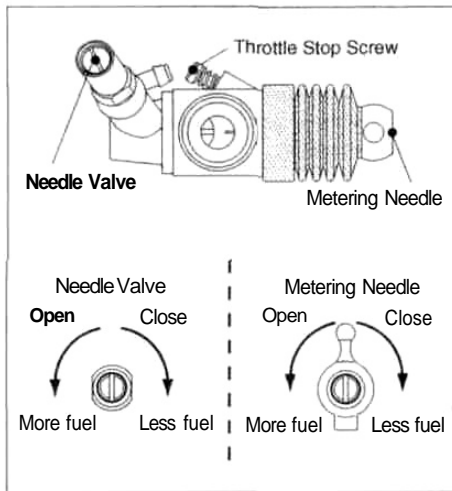

- ◆ Run the vehicle (with throttle fully open) over the longest available straight course, in order to observe the model's speed. Next return the car to the starting point, close the Needle-Valve 30° and repeat the run, taking note of the improvement in performance.
- ◆ Continue with further runs, gradually reducing the Needle-Valve setting and aiming to achieve the highest straight-line speed. Remember, however, that, if the Needle-Valve is shut down too far, the engine will overheat and, accompanied by visibly diminished exhaust smoke, the model will lose speed. At this point, throttle down immediately, stop the vehicle and reopen the Needle-Valve 45-90° .

- ◆ With the engine running, close the throttle and allow it to idle for about five seconds, then reopen the throttle fully. If, at this point, the engine puffs out an excessive amount of smoke and the vehicle does not accelerate smoothly and rapidly, it is probable that the idling mixture is too rich. In this case, turn the Metering Needle clockwise 45-90°. If, on the other hand, the engine tends to speed up momentarily and then cut out abruptly when the throttle is opened, the idling mixture is too lean. Correct this by turning the Metering Needle counter-clockwise 45-90°.

NOTE:

Metering Needle adjustment should be made in steps of not more than 45-90°, carefully checking the effect on throttle response, of each small adjustment.

- ◆ Carry out adjustments patiently, under actual running conditions, until the engine responds quickly and positively to the throttle control.

Warning!

Mixture adjustments (whether via the Metering Needle, or the Needle-Valve) cannot be made accurately under 'no-load' conditions, which, in any case, are not advised, since such operation carries the risk of seriously damaging the engine through over-revving and overheating.

- ◆ With the optimum mixture control position, light smoke is visible during high speed running, and the engine rpm increases smoothly during acceleration. Remember that, if the engine is operated with the fuel/air mixture slightly too lean, it will overheat and run unevenly. As with all engines, it is advisable to set both the needle-valve and metering needle very slightly on the rich side of the best rpm setting, as a safety measure.
- ◆ If the engine runs too fast with the throttle closed, the throttle stop screw should be turned counter-clockwise to allow the throttle opening to be reduced.

- ◆ Finally, beyond the nominal break-in period, a slight readjustment toward a leaner needle setting may be required to maintain maximum performance.

CARBURETOR CLEANLINESS

The correct functioning of the carburetor depends on its small fuel orifices remaining clear.

◆ REALIGNMENT OF METERING NEEDLE AND MIXTURE CONTROL VALVE

In the course of making carburetor adjustments, it is just possible that the Metering Needle and the Mixture Control Valve may be inadvertently screwed in or out too far and thereby moved beyond its effective adjustment range.

The basic positions can be found by rotating the Metering Needle until its slotted head is flush with the ball link body.

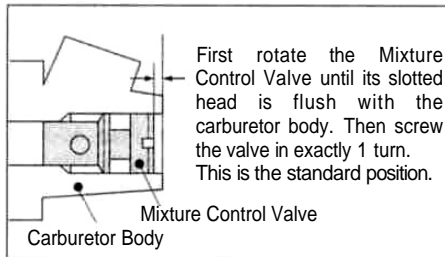
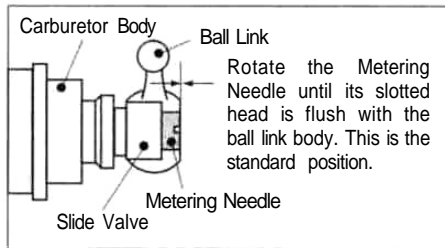

CARE AND MAINTENANCE

1. The minute particles of foreign matter, that are present in any fuel may, by accumulating and partially obstructing fuel flow, cause engine performance to become erratic and unreliable.

O.S. 'Super-Filters' (large and small) are available, as optional extras, to deal with this problem.

One of these filters installed to the pickup tube inside your refueling container, will prevent the entry of foreign material into the fuel tank. It is also recommended that a good in-line filter be installed between the tank and carburetor.

2. Do not forget to clean the filters regularly to remove dirt and lint that accumulate on the filter screens. Also, clean the carburetor itself occasionally.

3. At the end of each operating session, drain out any fuel that may remain in the fuel tank. Afterwards, energize the glow-plug and try to restart the engine, to burn off any fuel that may remain inside the engine. Repeat this procedure until the engine fails to fire. Do this while the engine is still warm.

4. Then, inject some after-run oil into the engine, and rotate the engine with an electric starter for 4 to 5 seconds to distribute the oil to all the working parts.

Note:

Do not inject after-run oil into the carburetor as this may cause the O-rings inside the carburetor to deteriorate. These procedures will reduce the risks of starting difficulties or corrosion after a period of storage.

5. Finally, when cleaning the exterior of the engine, use methanol or kerosene. Do not use gasoline or any solvent that might damage the silicone fuel tubing.

Caution:

The rear crankshaft bearing of this engine uses a special plastic retainer. If the front housing needs to be heated to remove or replace the bearing, do not allow the bearing to exceed 120°C (248°F), otherwise it may be damaged and rendered unserviceable.

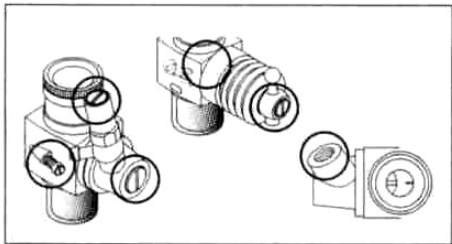

■ Fitting Dust Caps

When storing the engine, fit it to exhaust port, carburetor, etc. to prevent dust entering inside the engine.

CHECKING THE ENGINE

Engine will not develop normal performance after long time running due to wearing of parts. It is suggested to replace necessary parts when the following symptoms are detected.

- ◆ Engine sound changes and easily overheats.
- ◆ Power has dropped extremely.
- ◆ Idling is unstable and/or engine tends to stop at idling.

In most cases, ball bearings, cylinder & piston assembly, connecting rod and/or crankcase have become worn out or abnormal. Check the parts carefully and replace them if necessary.

GUARANTEE

This engine is constructed from the very best materials available and to the very highest engineering standards, using the most advanced precision machinery. However, the extremely high stresses imposed by car racing operation under very severe conditions, as well as stresses which are exacerbated by the use of powerful fuels containing very high concentrations of nitromethane, constitute hazards which are beyond a manufacturer's control. Accordingly, we regret that it is not possible to extend our usual warranty terms to this particular engine -i.e. no guarantee is offered against material wear, or damage resulting therefrom, in actual use.

TROUBLE SHOOTING

		Symptom
		Engine fails to fire.
Cause	Corrective action	
Fuel tank is empty. Fuel not reaching the engine.	Fill the tank with fuel and repeat Priming procedure.	
Glowplug element is burnt out. Glowplug battery discharged	Replace glowplug. Recharge or replace the battery.	
Clogged fuel filter Air cleaner and silencer inside is dirty.	Clean or replace fuel filter. Replace cleaner element and clean inside silencer.	
Over priming	Remove glowplug and pump excess fuel.	
Fuel tubing is disconnected. Fuel tubing is kinked, split or has a hole.	Connect fuel tubing securely. Check the tubing carefully and replace if necessary.	
Incorrect carburetor settings	Return the metering needle and mixture control valve to basic position.	
Incorrect servo linkage	Re-linkage after setting servo at neutral.	
Reverse rotating direction of starter box.	Make sure it rotates counter clockwise seen from crankshaft side.	

Symptom	
Engine fires intermittently but does not run.	
Cause	Corrective action
Insufficient fuel in the tank.	Fill the tank with fuel.
Deteriorated glowplug	Replace glowplug.
Clogged fuel filter Air cleaner and silencer inside is dirty.	Clean or replace fuel filter. Replace cleaner element and clean inside silencer.
Engine overheated	Wait until engine is cooled.
Incorrect clutch release	Adjust the tension of clutch spring.
Too immediately disconnecting plug battery	Do not disconnect plug battery and wait until r.p.m. become stable.
Fuel in the tank extremely bubbled	Fit O rings to the tank screws to prevent bubbles.

Symptom	
Unstable idling	
Cause	Corrective action
Unsuitable glowplug	Use suggested glowplug in the instructions.
Unsuitable fuel	Do not use extremely high nitro or low oil fuel.
Extremely light flywheel	Add suitable load.
Silencer is disconnected or has play	Install silencer securely.
Symptom	
Not reaching expected peak r.p.m.	
Cause	Corrective action
Insufficient warming up or running-in.	Set the needle only after warming up. Complete running-in.
Silencer or manifold is not securely connected or disconnected.	Replace seal ring. Check the connections and secure them.
Fuel tubing from tank to is split or broken.	Replace the tubing.

Symptom	
Poor response	
Cause	Corrective action
Deteriorated glowplug	Replace glowplug.
Incorrect carburetor settings	Readjust low r.p.m. range with metering needle and mixture control valve.
Incorrect setting of transmitter Exponential function.	Check the transmitter setting.
Symptom	
Poor r.p.m. drop	
Cause	Corrective action
Too much throttle opening at idling.	Close metering needle to adequate position to lower idling r.p.m.
Incorrect carburetor fitting	Fit carburetor securely.

ENGINE EXPLODED VIEW

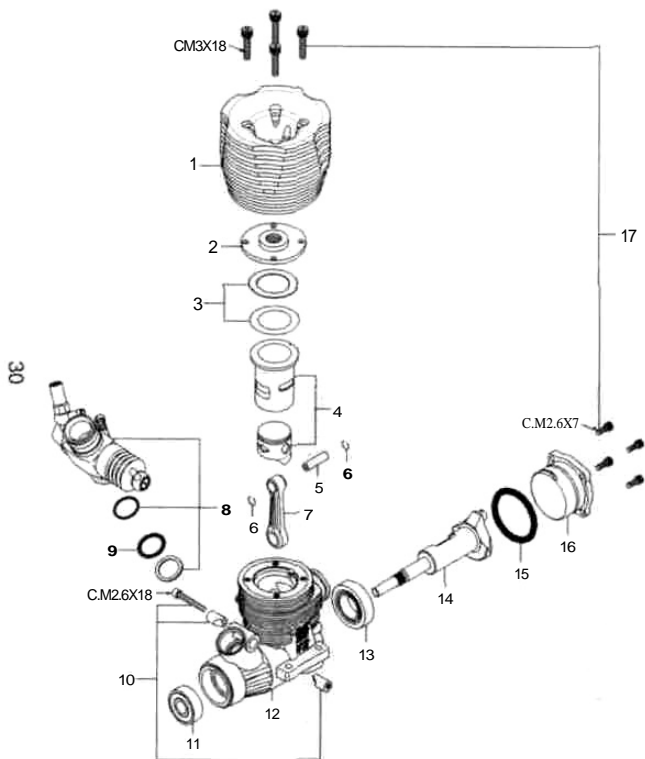

*Type of screw C—Cap Screw M--Oval Fillister-Head Screw
 F—Flat Head Screw N—Round Head Screw S—Set Screw

ENGINE PARTS LIST

No.	Code No.	Description
1	22105000	Outer Head
2	22105100	Inner Head
3	123764010	Head Gasket (2pcs.)
4	22103010	Cylinder & Piston Assembly
5	23906000	Piston Pin
6	23817000	Piston Pin Retainer (2pcs.)
7	23755000	Connecting Rod
8	23818050	Carburetor Complete (Type 21 C)
9	23715000	Carburetor Sealing Gasket
10	23981700	Carburetor Retainer Assembly
11	23731000	Crankshaft Ball Bearing (Front)
12	23751010	Crankcase
13	23730010	Crankshaft Ball Bearing (Rear)
14	22102000	Crankshaft
15	23764020	Cover Gasket
16	23757000	Cover Plate
17	23763010	Screw Set
	71641300	Glow Plug T-P3
	22826140	Exhaust Seal Ring
	71533000	Carburetor Reducer 8mm (RED) w/ "O" Ring (2pcs.)
	22884250	Dust Cap Set (3mm, 16mm, 18mm)

The specifications are subject to alteration for improvement without notice.

CARBURETOR EXPLODED VIEW

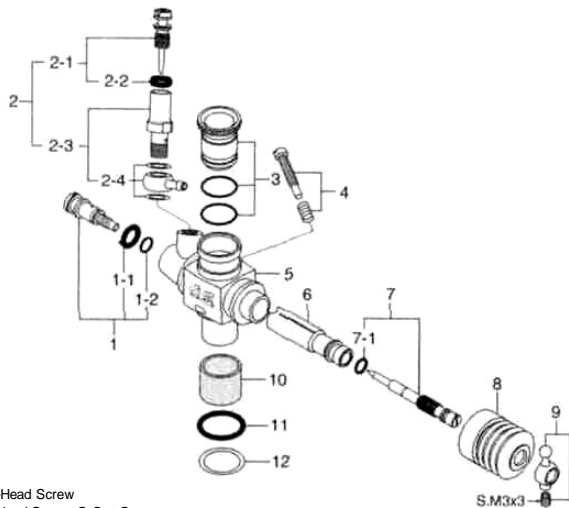

* Type of screw

C. Cap Screw M Oval Fillister-Head Screw

F.Flat Head Screw N.Round Head Screw S.Set Screw

CARBURETOR PARTS LIST

No.	Code No.	Description
1	23781600	Mixture Control Valve Assembly
1-1	46066319	"0" Ring (L) (2pcs.)
1-2	22781800	"0" Ring (S) (2pcs.)
2	23618190	Needle Valve Assembly
2-1	23618197	Needle Assembly
2-2	46066319	"0" Ring (2pcs.)
2-3	23618194	Needle Holder Assembly
2-4	23818176	Fuel Inlet (No.9)
3	71533010	Carburetor Reducer 9mm (BLUE) w/ "0" Ring (2pcs.)
4	23818500	Throttle Stop Screw
5	23818130	Carburetor Body (w/Thermo Insulator)
6	23781200	Slide Valve
7	23818340	Metering Needle Assembly
7-1	27881820	"0" Ring (2pcs.)
8	22884220	Dust Cover
9	23781400	Ball Link No.3
10	23781110	Thermo Insulator
11	29015019	Carburetor Rubber Gasket
12	23818190	Carburetor Sealing Washer

The specifications are subject to alteration for improvement without notice.

■ GLOWPLUG

- P3** (71641300) **P6** (71641600)



■ T-2050 EXHAUST HEADER PIPE ASSEMBLY

(72106150)

- Exhaust Header Pipe (72106155)
- Header Pipe Spring (2pcs.) (72101272)
- Exhaust Seal Ring (2pcs.) (22826140)

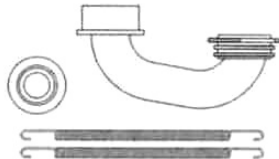

■ T-2050 TUNED SILENCER ASSEMBLY

(72106060)

- T-2050 Tuned Silencer Body (72106061)
 Pressure Nipple (72106041)
- Exhaust Seal Ring (2pcs.) (22826140)
- Joint Spring (3pcs.) (72106042)

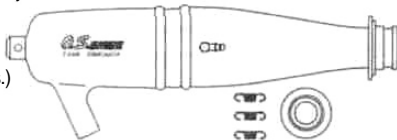

■ T-2050 TUNED SILENCER COMPLETE SET

(72106070)

- T-2050 Tuned Silencer Assembly (72106060)
- T-2050 Exhaust Header Pipe Assembly (72106150)

The specifications are subject to alteration for improvement without notice.

- **T-2030 TUNED SILENCER**
(72106030)

- **21RZ
EXHAUST HEADER PIPE**
(72101270)

- **SUPER JOINT TUBE 21**
(72106300)

- **SUPER AIR CLEANER 203**
(72413000)

- 203 Filter Element (4pcs.)
(72413200)



- **EXHAUST SEAL RING**
(22826140) (2pcs.)



- **CAP SCREW SET**
M2.6x7(10pcs.)
(79871020)



- **DUST CAP SET**
3mm (5pcs.) (73300305)
8mm (3pcs.) (73300812)
16mm (3pcs.) (73301512)
18mm (3pcs.) (73301812)



- **CRANKSHAFT CLAMP**
1521
(71530200)



- **LONG SOCKET WRENCH**
WITH PLUG GRIP
(715210001)

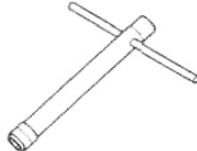

The specifications are subject to alteration for improvement without notice.

THREE VIEW DRAWING

SPECIFICATIONS

■ Displacement	3.46cc(0.211cu.in.)
■ Bore	16.6mm (0.654in.)
■ Stroke	16.0mm (0.630in.)
■ Practical R.P.M.	3,000-40,000 r.p.m.
■ Power output	2.48ps / 33.000 r.p.m.
■ Weight	360g (12.7oz.)

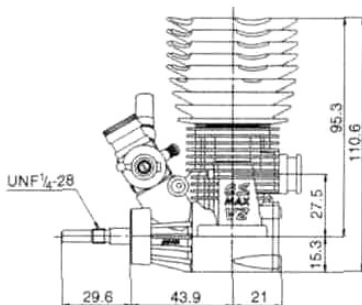
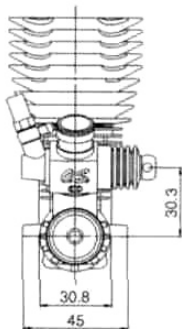
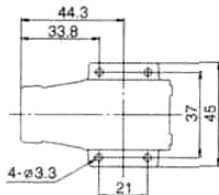
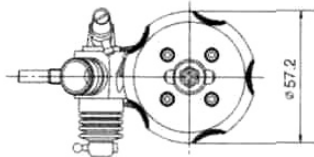

Dimensions (mm)



***O.S. ENGINES* MFG.CO.,LTD.**

6-15 3-Chome Imagawa Higashisumiyoshi-ku
Osaka 546-0003, Japan TEL. (06) 6702-0225

FAX. (06) 6704-2722

URL: <http://www.os-engines.co.jp>