

# ZENMUSE H3-2D Gimbal

## User Manual<sup>V1.02</sup>

For Firmware V1.00& Assistant SoftwareV1.00

2013.06.19 Revision

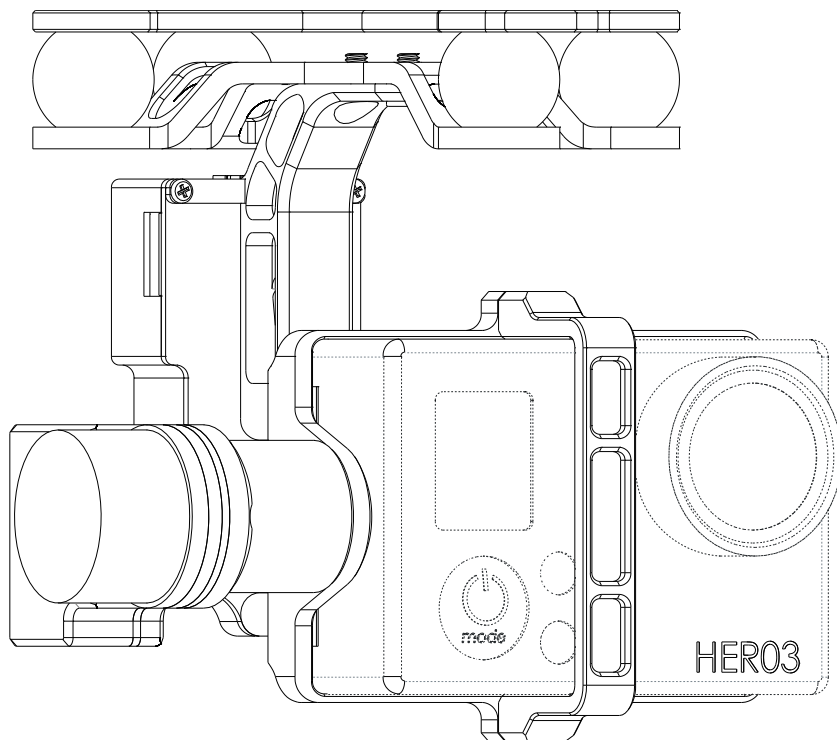

[www.dji-innovations.com](http://www.dji-innovations.com)

# Warning & Disclaimer

## No adjusting or amending is allowed to the H3-2D!!!

H3-2D is specialized for Camera and Lens before it leaves the factory. Please mount your camera to H3-2D when get it. No adjusting or amending is allowed to H3-2D. Do not modify or add any other component/device (such as filter, lens hood, etc.) to the camera; make sure to use the original battery; otherwise it may end up with worse performance or even internal malfunction.

The gimbal can only work with Autopilot system specified by DJI Innovations (NAZA-M/NAZA-M V2/WooKong-M), so as to ensure the highest stability and precision. Please download the corresponding assistant software and upgrade the autopilot system MC firmware, otherwise may lead the gimbal work abnormally.

Make sure the Autopilot system operates in the safest manner when the main power battery is connected. We strongly recommend customers to remove all propellers, use power supply from R/C system or flight pack battery, and keep children away during gimbal calibration and parameter setup. Please strictly follow these steps to mount and connect gimbal on your aircraft, as well as to install the assistant software on your computer. Please respect the AMA's National Model Aircraft Safety Code.

As DJI Innovations has no control over use, setup, final assembly, modification (including use of non-specified DJI parts i.e. motors, ESCs, propellers, etc.) or misuse, no liability shall be assumed nor accepted for any resulting damage or injury. By the act of use, setup or assembly, the user accepts all resulting liability. DJI assumes no liability for damage(s) or injuries incurred directly or indirectly from the use of this product.

DJI and H3-2D are registered trademarks of DJI Innovations. Names of product, brand, etc., appearing in this manual are trademarks or registered trademarks of their respective owner companies. This product and manual are copyrighted by DJI Innovations with all rights reserved. No part of this product or manual shall be reproduced in any form without the prior written consent or authorization of DJI Innovations. No patent liability is assumed with respect to the use of the product or information contained herein.

## Product Profile

This product is an excellent gimbal designed for AP. Excellent job can be done by this gimbal. The gimbal has built-in slip ring in the mechanical structure, preventing wire rod from winding up. It also has built-in independent IMU module, special servos drive module, etc.

# In The Box

## Gimbal×1

The gimbal has built-in special servos drive module, and independent IMU module. It controls both the tilt and the roll axis, to enhance the attitude stabilization.

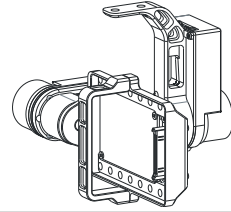

## Damping Unit×1

Connect the aircraft and the gimbal, in order to reduce the mechanical vibration. There are three types of Vibration Absorber, the White is softest, the Black is hardest, and the Grey is in the middle. It is recommended to use the White on DJI F450, not use any on DJI F550, and the DJI PHANTOM can use any type.

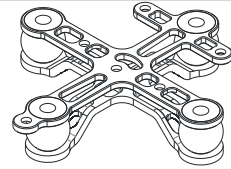

## Gimbal Controller Unit (GCU)×1

Connect the gimbal controller to the autopilot system by CAN-Bus. And Use the 3S-6S power cable to supply power for the GCU and gimbal.

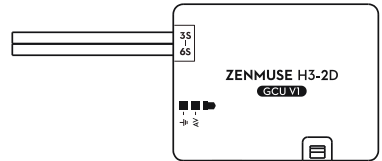

## Screw Package ×1

M2.5x6.3: For fixing the camera to the gimbal.

M2.5x5: For fixing the gimbal to the damping unit.

M3x8 (with M3 nuts and M3 spacers): For mounting the damping unit to the aircraft.



## Gimbal Video Power Cable×1

For the gimbal controller unit and your Wireless Video Transmission Unit connecting, transmitting the video signal.



## CAN-Bus Cable×1

Use CAN-Bus to communicate with the autopilot system.



## 8-Pin Cable×1

For the gimbal and the GCU connecting,



## Spare Package×1

Spare Screw

# Index

<b>WARNING &amp; DISCLAIMER</b> .....	<b>2</b>
<b>PRODUCT PROFILE</b> .....	<b>2</b>
<b>IN THE BOX</b> .....	<b>3</b>
<b>INDEX</b> .....	<b>4</b>
<b>ASSEMBLY</b> .....	<b>5</b>
GIMBAL DESCRIPTION .....	5
STEP1.    MOUNT THE GIMBAL TO THE AIRCRAFT OR LANDING GEAR .....	5
STEP2.    MOUNT THE CAMERA TO THE GIMBAL.....	7
STEP3.    DOUBLE CHECK .....	7
<b>AUTOPILOT SYSTEM, GCU AND GIMBAL WIRING</b> .....	<b>8</b>
GCU PORT DESCRIPTION .....	8
STEP1.    CONNECT GCU AND AUTOPILOT SYSTEM .....	8
STEP2.    VIDEO SIGNAL TRANSMISSION.....	11
<b>ASSISTANT</b> .....	<b>12</b>
STEP1.    INSTALL DRIVER AND SOFTWARE .....	12
STEP2.    GUI .....	12
STEP3.    CHANNEL SETTING .....	12
STEP4.    FIRMWARE & SOFTWARE UPGRADE .....	13
<b>TEST</b> .....	<b>14</b>
STEP1.    CHECK LIST BEFORE EVERY FLIGHT .....	14
STEP2.    TEST .....	14
<b>APPENDIX</b> .....	<b>15</b>
TROUBLE SHOOTING .....	15
SPECIFICATIONS.....	16

# Assembly

## Gimbal Description

### Notes:

- (1) Make sure nothing blocks the servo driver module rotation, to avoid Servo Driver Module damage.
- (2) Clear obstacle at once if the rotating gimbal is blocked.

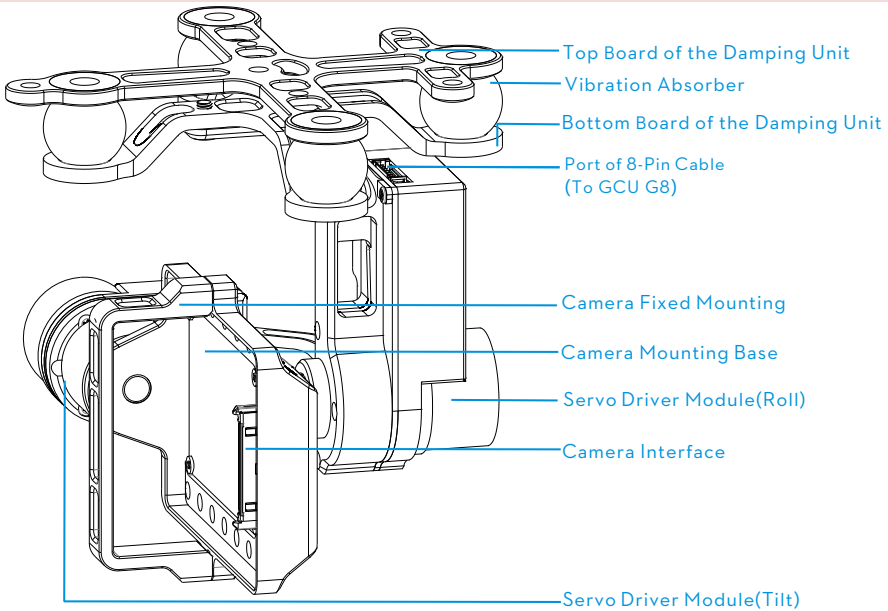

## STEP1. Mount the Gimbal to the Aircraft or Landing Gear

The following procedure applies to DJI F450, DJI other type of aircraft or to your own aircraft. For DJI F450, there are diagrams for your reference.

1. Attach the Vibration Absorber to the Top Board of Damper Unit shown in Fig.1.
2. Mount the Top Board of Damper Unit to the Bottom Board of aircraft; fix the M3x8 screws, M3 spacers and M3 nuts shown in Fig.2.
3. Plug one port of the 8-Pin cable into the 8-Pin port on the gimbal shown in Fig.3.
4. Tighten the M2.5x5 screws to fix the gimbal to the Bottom Board of Damper Unit shown in Fig.4.
5. Attach the Vibration Absorber to the Bottom Board of Damper Unit shown in Fig.5.
6. Make sure the top and bottom plates of damping unit stay parallel when mounting, preventing the damping units from stretched and distorted.

### Notes:

- (1) This product does not include any extra aircraft, landing gear or camera, please prepare them by yourself.

- (2) Make sure the Camera Mounting Base is pointing to the aircraft nose direction.
- (3) The gimbal center of gravity has been set, whose position directly determine gimbal performance. Please do not adjust the gimbal center of gravity by yourself.
- (4) The gimbal is high-precision controlled. Do not remove any other screws in the gimbal, which may result in bad performance or even damage.
- (5) Do not unplug any cable attaching to the gimbal ports, or even change the mechanical structure.

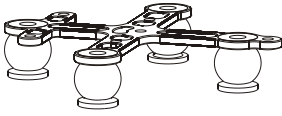

Fig.1

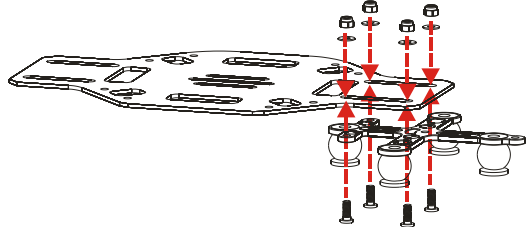

Fig.2

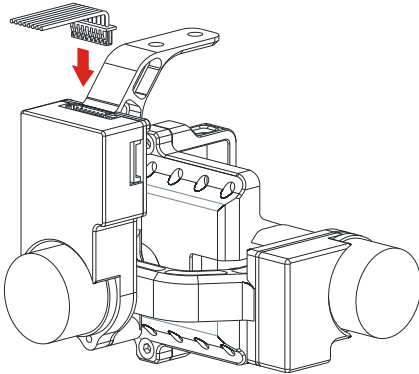

Fig.3

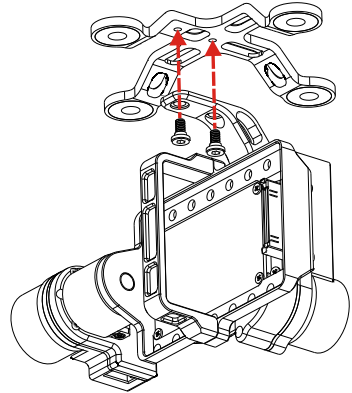

Fig.4

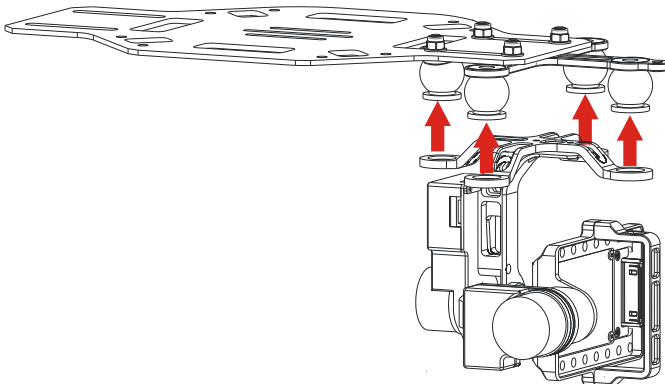

Fig.5

## STEP2. Mount the Camera to the Gimbal

1. Mount the camera into the Camera Mounting Base of gimbal and fix the camera by the Camera Fixed Mounting, shown as Fig.1.
2. Plug the Camera Interface of gimbal into the System Port of camera, and make sure they are in good contact, which are marked in Red shown as Fig.2.
3. Tighten the M2.5x6.3 screw , shown as Fig.3.
4. Please put you hand at the position in red mark shown as Fig.4, and then remove the camera from gimbal with appropriate strength, as the Camera Interface is easily damaged.

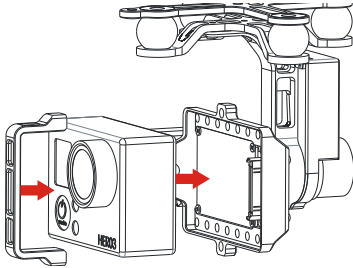

Fig.1

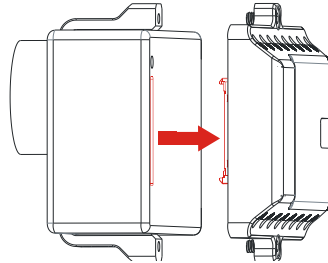

Fig.2

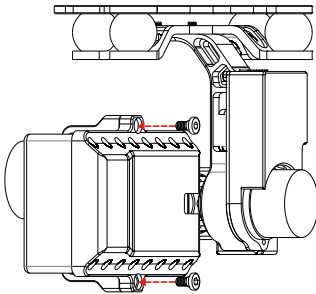

Fig.3

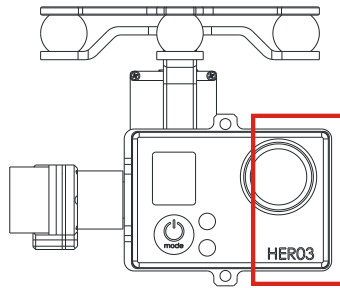
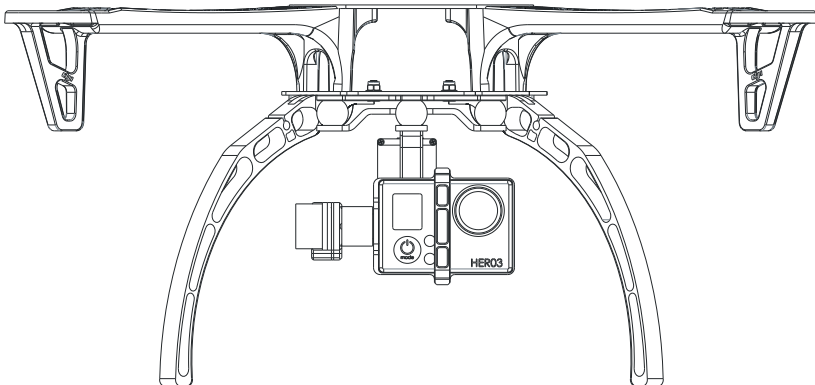

Fig.4





## STEP3. Double Check

Make sure the Lens of camera is pointing to the aircraft nose direction.



# Autopilot System, GCU and Gimbal Wiring

## GCU Port Description

Gimbal Controller Unit (GCU) Port Description	
	To the battery. Power for the GCU and gimbal.
	To Gimbal, transmitting the signal.
	Micro-USB port: PC connection for configuration and firmware upgrades.
	CAN-Bus port: Use a CAN-Bus cable to connect the GCU to the autopilot system.
	To Wireless Video Transmission Module, transmitting the Video signal.

## STEP1. Connect GCU and Autopilot System

Carry out the following procedures to finish the connection.

- Keep the Autopilot system in the same state as it was, and upgrade the Main Controller to the latest Firmware (shown as the following table).

	WKM	NAZA-M V2	NAZA-M
Assistant Software	V2.00(or above)	V2.12(or above)	V2.12(or above)
Firmware Version	V5.22(or above)	V3.12(or above)	V3.12(or above)

- Connect the Autopilot System (shown as the following table). For NAZA-M user, you are asked to prepare a PMU V2 module (Accessory of NAZA-M V2) and do some reconnection of the system.

	WKM	NAZA-M V2	NAZA-M
(1) Main Controller and PMU connection	Connect the X1 port of PMU to X1 port of Main Controller.	Connect the X3 port of PMU V2 to X3 port of Main Controller.	
(2)PMU Power Cable connection	Connect the Power Cable to a connector, if DJI Multi-rotor is used, solder the power cable to the power pad on aircraft.		
(3) GPS/Compass module and Autopilot system connection	Connect the GPS/Compass module to any spare CAN-Bus port on PMU.	Connect the GPS/Compass module to the GPS port of PMU V2.	

Please refer to the following diagrams for more GCU connection details. And refer to the Autopilot system manual for more connection and configuration details.

- Connect the GCU to Autopilot System. And then connect the 8-Pin cable of gimbal to the G8 port of GCU.

	WKM	NAZA-M V2	NAZA-M
(1) GCU and Autopilot System connection	Connect the GCU to any spare CAN-Bus port on the WKM system.	Connect the GCU to the CAN-Bus port on the PMU V2 module.	



(2) GCU Power Cable connection	Connect the GCU Power Cable to a connector, if DJI Multi-rotor is used, solder the power cable to the power pad on aircraft.	
(3) Gimbal TILT Control channel	X2	X1

4. Connection has been finished. They can come into use after power on.
5. The tilt direction of gimbal can be controlled by one channel of Autopilot System (WKM is X2, NAZA-M and NAZA-M V2 is X1). You are asked to set the corresponding channel on your Transmitter, and connect the corresponding port of Receiver to the Main Controller. Use the Gimbal Assistant Software to help you with configuration.

**Notes:**

- (1) Re-do the Transmitter calibration after NAZA-M Firmware upgrade and double check other items.
- (2) Make sure to power on the gimbal after camera mounting, since the wrong center of gravity will cause motor overheating and then lead to damage.
- (3) Make sure connections are correct; otherwise may lead to the gimbal normal work or even out of control.

**GCU and DJI Autopilot System Connection**

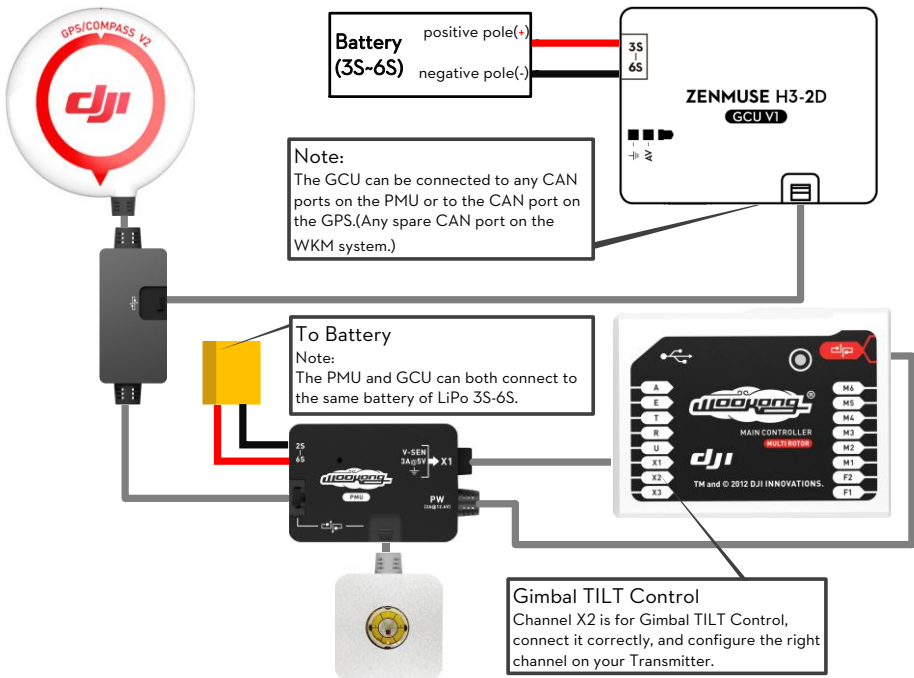

Fig.1 GCU and WKM Connection Diagram

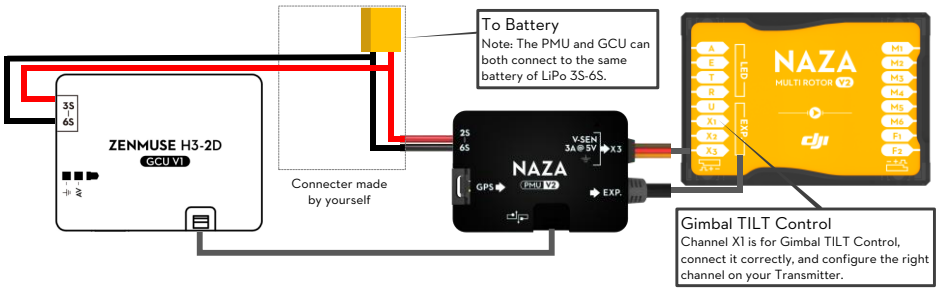

Fig.2 GCU and NAZA-M V2 Connection Diagram

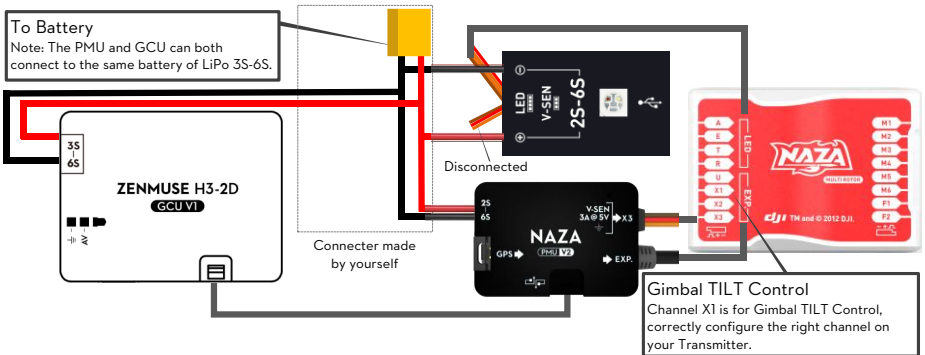
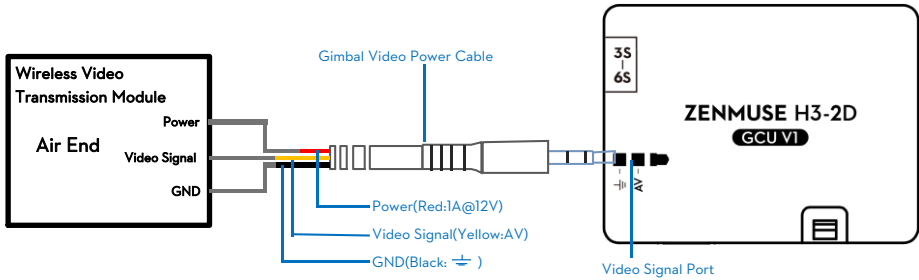

Fig.3 GCU and NAZA-M Connection Diagram with PMU V2 (NAZA-M V2 Accessory)

## STEP2. Video Signal Transmission

A wireless video transmission module is necessary for video signal accessing remotely.



1. Respectively solder the Power/Video Signal/GND cables to wireless video transmission module (Air End).
2. Plug the gimbal video power cable head into the GCU Video Signal Port.

### Notes

- (1) Make sure to connect Wireless Video Transmission Unit to GCU first, then power on.
- (2) The standard gimbal video power cable is recommended. Make sure you solder the gimbal video power cable to the wireless video transmission unit correctly, to avoid the 12V power burn the gimbal or your own device. And ensure the cables are insulated, to prevent from short circuit.

█ Power Cable(1A @12V)

█ Video Signal Cable(AV)

█ GND Cable

- (3) Ensure the 12V power is safe for you own device when using other power cable.
- (4) Make sure the wireless video transmission module current consumption does not exceed 1A, to prevent the GCU from damage.

### Tips:

- (1) Following diagram shows how video signal transit when gimbal working.
- (2) If video signal access fails, please check each step.

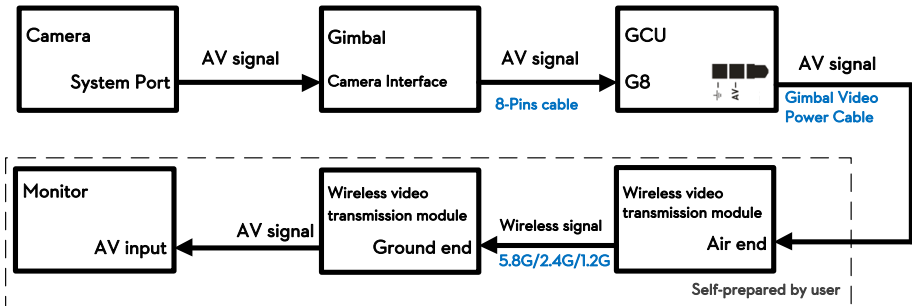

# Assistant

## STEP1. Install Driver and Software

1. Make sure driver is installed correctly, which has been installed before you use WooKong-M, NAZA-M or NAZA-M V2.
2. Please download H3-2D gimbal assistant software from DJI Innovations website.
3. Click assistant software Installer and follow the steps to finish installation.
4. Run the assistant software.

## STEP2. GUI

Connect GCU and PC via a Micro-USB cable, power on GCU.

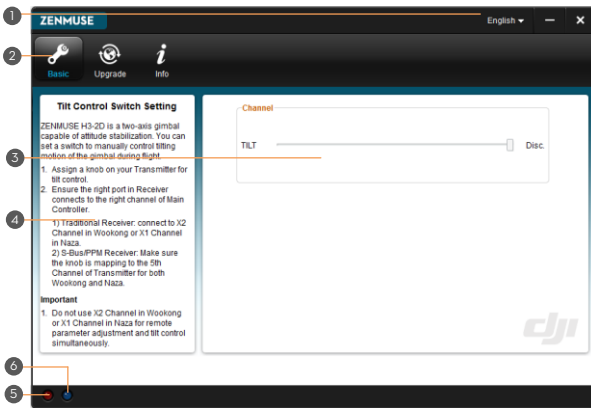

### 1 Language

- 中文 or English

### 2 Menu

- Basic: Basic function setting
- Upgrade: For upgrading the gimbal firmware
- Info: For version and SN access

### 4 Text Description

- Mouse over each item on the 3 area will display the corresponding content

### 5 Connection indicator

- Red LED On: Disconnected with PC
- Green LED On: Connected with PC

### 6 Communication indicator

- Blue LED On: Without communication
- Blue LED Blink: Communicating with PC

## STEP3. Channel Setting

**TILT:** Slide the TX switch, the corresponding slider of cursor will move, and you can see the gimbal moving by rotating the pitch axis, shown as the following chart.

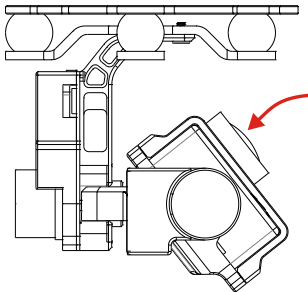

Fig.1 Moving Upwards

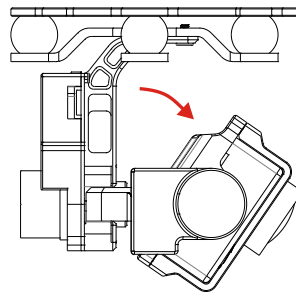

Fig.2 Moving Downwards

## STEP4. Firmware & Software Upgrade

### Firmware Upgrade

Please strictly follow the operation procedures for firmware upgrade; otherwise the gimbal might not work properly.

1. Make sure your computer is connected to the Internet.
2. Please close all the other applications during firmware upgrade, including anti-virus software and firewall.
3. Make sure the power supply is securely connected. DO NOT un-plug the power supply until firmware upgrade has finished.
4. Connect the GCU to PC with a Micro-USB cable, DO NOT break connection until firmware upgrade has finished.
5. Run the Software and wait for connection.
6. Select **Upgrade** → Main Control, IMU and CMU.
7. DJI Innovations server will check current firmware version, and get the latest firmware prepared for the unit.
8. If there is a firmware version more up-to-date than your current version, you will be able to click the Upgrade Version.
9. Wait until Assistant software finishes Upgrade.
10. Click **OK** and power cycle the unit after at least 5 seconds.

### Notes:

- (1) It is recommended to disconnect the connection between the GCU and autopilot during IMU and CMU upgrade.
- (2) After firmware upgrade, please re-recognize setup using Assistant software.
- (3) If it is notified that the network or DJI Innovations server is busy, please try again later with above procedures.
- (4) If firmware upgrade failed, please try again with the above procedures.

### Software Upgrade

Click Info → Software Info, if there is a software version more up-to-date than your current version, you will be able to download the Upgrade Version.

You can also check the product version via Info → SN. This includes Hardware ID , IMU , GCU , Software.

SN is a 32 digits authorization code for unit function activations. We had already filled in the authorization code for your unit after manufacture. You might be asking to fill in the new SN in the future if you brought new function upgrades. Fill in the SN and then click Write button. If you filled in an invalid SN over 30 times, your product will be locked and you have to contact our customer support.

# Test

## STEP1. Check List Before Every Flight

**For safety reasons, please pay serious attention to all following items Before Every Flight.**

- (1) Gimbal is installed firmly to aircraft, and camera mounted correctly and stably. Make sure the Lens of camera is pointing to the aircraft nose direction.
- (2) All cables are in correct and firm connection, without anyone in backwards.
- (3) Gimbal video power cable is in good soldered condition if wireless video transmission module used. Make sure to connect Wireless Video Transmission Unit to GCU first, then power on.
- (4) Correct TX settings.
- (5) Correct camera settings.
- (6) Normal connection between GCU and autopilot system.
- (7) Upgrade Autopilot System MC Firmware.

## STEP2. Test

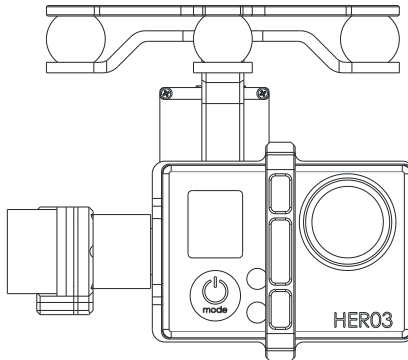

1. Make sure the batteries are fully charged for transmitter, GCU and all the other devices on your aircraft.
2. Switch on the TX.
3. Power on gimbal and wait for self-testing.
4. After initializing, camera lens will point to aircraft nose direction, that is, the three axes of gimbal should be in the condition as the above diagram shows.
5. Toggle the Tilt Control switch on your transmitter, and make sure it is working properly. Then try to feel if your gimbal moves to the corresponding direction. If not, check your settings.

### Note:

If the gimbal is abnormal (unlike the diagram shows) after initializing, turn to *Trouble Shooting* in *Appendix*.

Pay attention to the flight time and the electricity usage during flying.

# Appendix

## Trouble Shooting

NO.	What	Why	How to
1	Gimbal keeps drifting after initialization	(1) TX trims are too much (2)GCU and autopilot system is disconnected (3)Gimbal mounting direction is disaccording to aircraft nose	(1) Adjust the TX trims (2)Connect GCU and autopilot system (3)Ensure Gimbal mounting direction is the same with aircraft nose
2	The gimbal is abnormal after initializing	Abnormal calibration after manufacture	Please contact local dealer or DJI Innovations customer service
3	Can't distinguish gimbal pointing when using	BVR flight	Try to use a wireless video transmission module.

# Specifications

General	
Built-In Functions	<ol style="list-style-type: none"><li>(1) 2-axis gimbal</li><li>(2) DJI gimbal special servos drive module</li><li>(3) All aluminum alloy manufacture</li><li>(4) Built-in independent IMU module</li><li>(5) Light-weight</li><li>(6) WKM, NAZA-M, NAZA-M V2 ,PHANTOM supported</li><li>(7) GoPro3 supported</li><li>(8) Based on Zenmuse technology</li></ol>
Peripheral	
Supported Camera	GoPro3 Silver and Black
GCU Input Power	3S-6S LiPo
Assistant Software System Requirement	Windows XP SP3; Windows 7; Windows 8
Mechanical& Electrical Characteristics	
Working Current	<ul style="list-style-type: none"><li>● Static current: 400mA (@12V)</li><li>● Dynamic current: 600mA (@12V)</li></ul>
Gimbal Output Power	12V-16.8V
Operating Temperature	-10°C ~ 50°C
Gimbal Weight	230g(With GoPro3)
Gimbal Dimensions (With Damping Unit)	99.5mm ×85.5mm ×92.75mm
GCU Weight	22g
GCU Dimensions	42 mm X32 mm X9.3 mm
Working Performance	
Controlled Angle Accuracy	0.08°
Maximum Controlled Rotation Speed	Roll axis: 30°/s Tilt axis: 130°/s
Controlled Rotation Range	Roll axis control: 39° Tilt axis control: -130~+50°
Regulatory Approvals	
FCC (USA)	Yes
IC (Canada)	Yes
ROHS(EU)	Yes